

No. 852,369.

PATENTED APR. 30, 1907.

P. E. WIRT.
PRESS BAR LOCKING DEVICE.
APPLICATION FILED JULY 10, 1906.

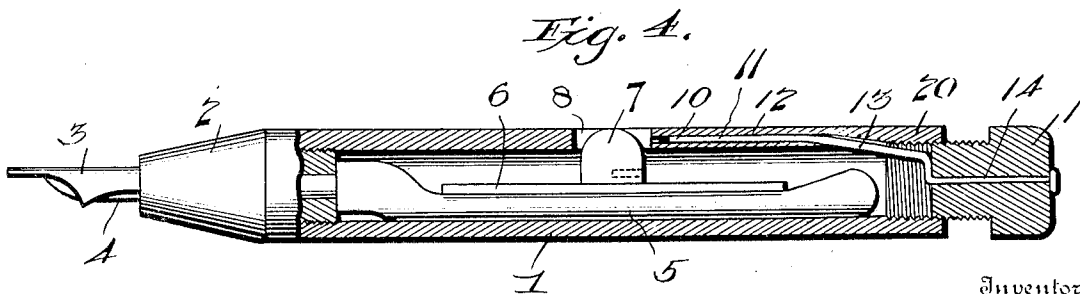
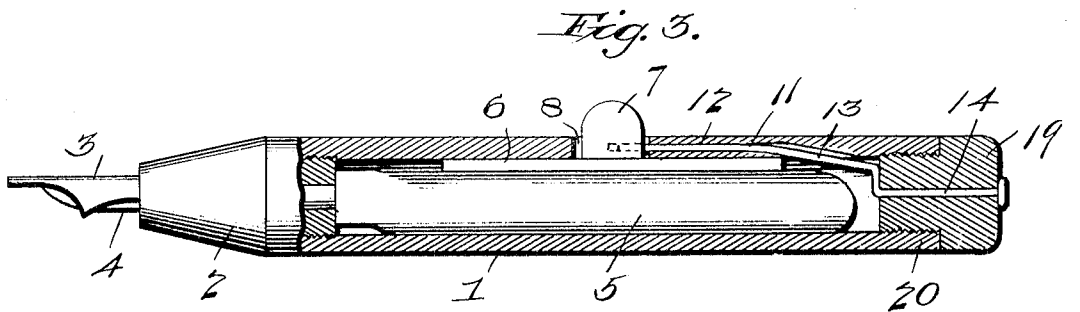
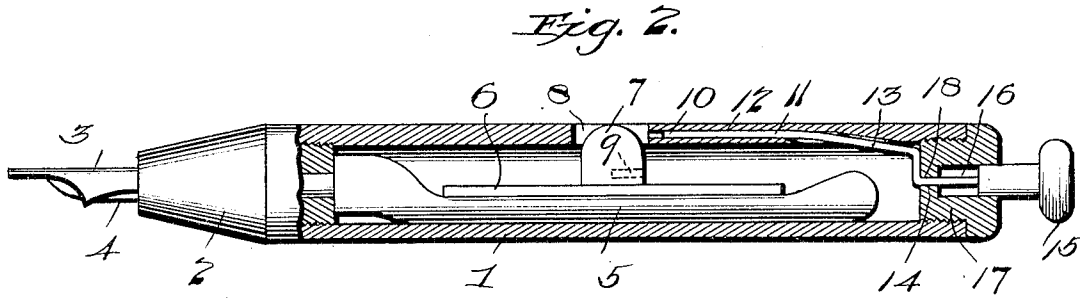
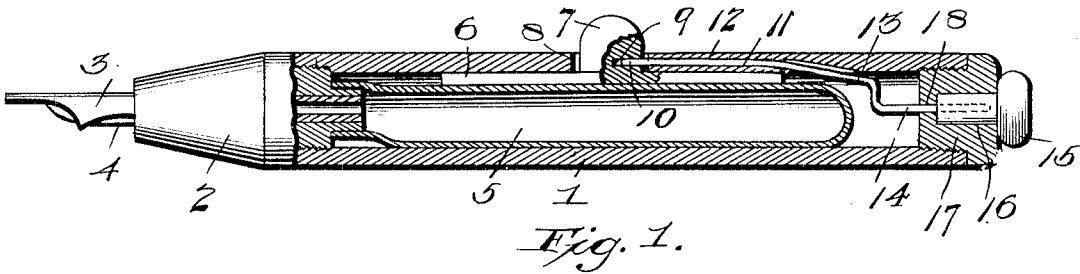

Inventor
Paul E. Wirt

Witnesses
J. L. Kordance
Wm W. Deane

By

D. P. Holhafter
Attorney

UNITED STATES PATENT OFFICE.

PAUL E. WIRT, OF BLOOMSBURG, PENNSYLVANIA.

PRESS-BAR-LOCKING DEVICE.

No. 852,369.

Specification of Letters Patent.

Patented April 30, 1907.

Application filed July 10, 1906. Serial No. 325,485.

To all whom it may concern:

Be it known that I, PAUL E. WIRT, a citizen of the United States, residing at Bloomsburg, in the county of Columbia and State of Pennsylvania, have invented certain new and useful Improvements in Press-Bar-Locking Devices, of which the following is a specification.

This invention relates to self-filling fountain pens and has special reference to an improved and practical construction of locking device for the presser bar and provides simple and effective means for fastening or locking the press bar in an inoperative position whereby the same is prevented from being accidentally moved from the handling or carrying of the pen.

To this end the invention provides a press bar locking device embodying a minimum number of parts, occupying a small amount of space, arranged entirely out of the way, while at the same time being freely manipulated by the operator from the upper end of the holder or case.

With these and many other objects in view which will more readily appear as the nature of the invention is better understood, the same consists in the novel construction, combination, and arrangement of parts herein-after more fully described, illustrated, and claimed.

The essential features of the invention involved in the employment of a longitudinally shiftable locking shaft or arm in connection with an operating head located at the upper end of the case, is susceptible to modification without departing from the scope of the invention, but a preferred embodiment thereof is shown in the accompanying drawings, in which:

Figure 1 is a longitudinal sectional view of a self-filling fountain pen equipped with a press bar locking device constructed and arranged in accordance with the present invention. Fig. 2 is a similar view showing the locking device released to permit compression of the collapsible reservoir. Figs. 3 and 4 are views similar to Figs. 1 and 2, showing a modification wherein a rotatable screw plug is employed as the operating head for advancing or withdrawing the longitudinally reciprocal locking shaft or arm.

Like references designate corresponding parts in the several figures of the drawings.

To illustrate the application of the improved locking device, there is shown in the

drawings an ordinary form of fountain pen including a reservoir holder or case 1 carrying the usual pen bearing section 2 fitted with the pen point 3, and the co-operating feeder 4. Also, in the pen shown the pen bearing section 2 has fitted to the interior end portion thereof the open end of the collapsible reservoir 5 consisting of the usual elastic sack having arranged at one side thereof the bodily movable press bar or plate 6.

The press bar or plate 6 is arranged longitudinally within the holder and bears against one side of the sack or reservoir on the exterior thereof. The said element 6 operates in the usual way for collapsing the sack to substantially the condition shown in Figs. 2 and 4 of the drawings for expelling the air and permitting the filling of the reservoir by atmospheric pressure in the manner common to this type of pens. After the reservoir sack is thus filled with its supply of ink, the present invention provides for securely locking the press bar in a normally retracted inoperative position, and this is accomplished by the employment of the improved locking device forming the subject matter of this application.

The locking device co-operates with a press button 7 rigidly secured to or carried by the press bar at a point intermediate the ends of the latter and is designed to move within a keeper opening or slot 8 provided in one side of the holder or case. The said button 7 is provided at one edge with a keeper element 9 preferably consisting of a catch opening or socket adapted to receive the inner catch end 10 of a longitudinally reciprocal locking shaft or arm 11.

The locking shaft or arm 11 preferably consists of a suitable length wire rod or bar arranged to slidably work in a guiding opening 12 bored or channeled out in the wall of the holder or case 1 and leading at one end directly into the keeper opening or slot 8 whereby the inner catch end 10 of the said locking shaft or arm is guided for movement into and out of the plane of said opening or slot 8. Hence, the catch 10 may be advanced into or withdrawn from the catch opening or socket constituting the keeper element 9 of the press button 7.

The outer or upper end portion of the locking shaft or arm 9 is deflected inwardly, as at 13, within the upper end portion of the holder or case and at such point is further provided with a handle stem 14 which is connected to

the operating head for controlling the locking device. In the form of the invention shown in Figs. 1 and 2 of the drawings, the operating head, designated by the reference number 15, consists of a headed slide pin or plug slidably working and seated in the guiding socket 16 formed in the outer side of the screw cap 17 threaded into the upper or outer end portion of the holder or case, and constituting a closure therefor. The said screw cap 17 is provided with a centrally bored guide 18 slidably receiving the handle stem 14 of the locking shaft, thereby providing a construction whereby the operating end portion of the locking shaft or wire is centered, while the main portion of the shaft is firmly anchored and guided by the extended guiding opening of the holder or case.

In the form of the invention described, it will be observed that it will be simply necessary to reciprocate the slide out and in to provide for withdrawing and advancing the locking shaft or arm according as it is desired to release or lock the press bar.

In the form of the invention shown in Figs. 3 and 4 of the drawings, the outer handle stem portion 14 of the locking shaft or arm is swiveled in a head 19 consisting of a screw plug adjustably screwed into the outer threaded end portion 20 of the holder or case. The rotation of said plug 20 necessarily provides for the longitudinal reciprocation of the locking shaft or arm to effect its disengagement from or engagement with the press button of the press bar.

Other modifications will readily suggest themselves to those familiar with the art, and it will be understood that various changes in the form, proportion, and minor details of construction may be resorted to without departing from the spirit or sacrificing any of the advantages of the invention.

I claim:

1. In a fountain pen, the holder having a side opening, and a longitudinally arranged guiding opening in its wall, a collapsible reservoir, a press bar having a press button, a reciprocal locking shaft slidably mounted in said guiding opening and arranged to engage and disengage said press button, and a shifting operating head supported at one end of the holder and connected with said shaft.

2. In a fountain pen, a holder having a side opening and a longitudinally arranged guiding opening leading into the side opening, a collapsible reservoir, a press bar having a projecting press button, a reciprocal locking shaft slidably mounted in said guiding opening and having an inner catch end arranged to engage and disengage said press button, and an operating head mounted at one end of the holder and connected with one end of the locking shaft.

3. In a fountain pen, a holder having a side opening, a longitudinally arranged guiding opening, a collapsible reservoir, a press bar having a projecting press button provided with a keeper element, a cap closing the upper end of the holder and provided therein with a guiding socket, an operating head consisting of a slide pin working in said socket, and a longitudinally reciprocal locking shaft slidably mounted in the guiding opening of the holder and at its outer end having a centrally disposed stem connected with and carried by the operating head, said locking shaft having an inner catch end movable into and out of engagement with said keeper element of the press button.

In testimony whereof I hereunto affix my signature in the presence of two witnesses.

PAUL E. WIRT.

Witnesses:

S. F. PEACOCK,
KARL F. WIRT.